

Show V_o waveform wrt V_{in} waveform.

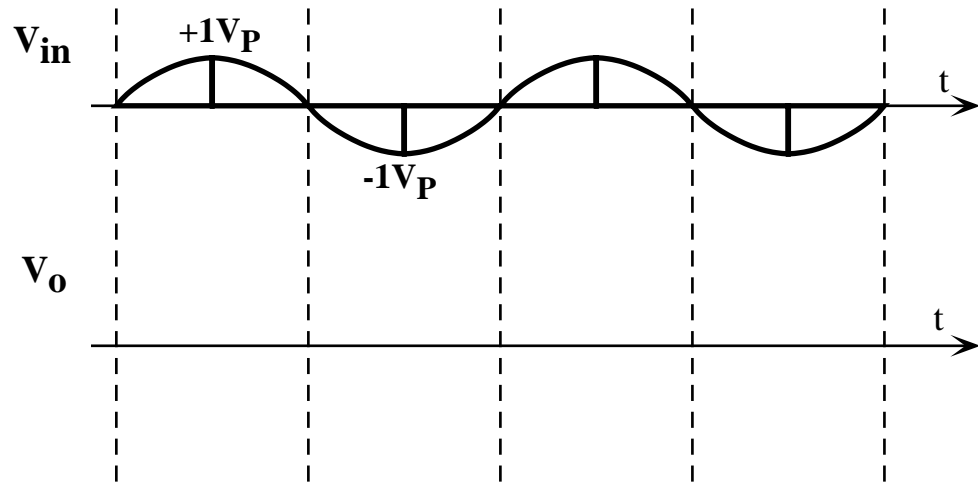

No.2

Positive V_{in}

Negative V_{in}

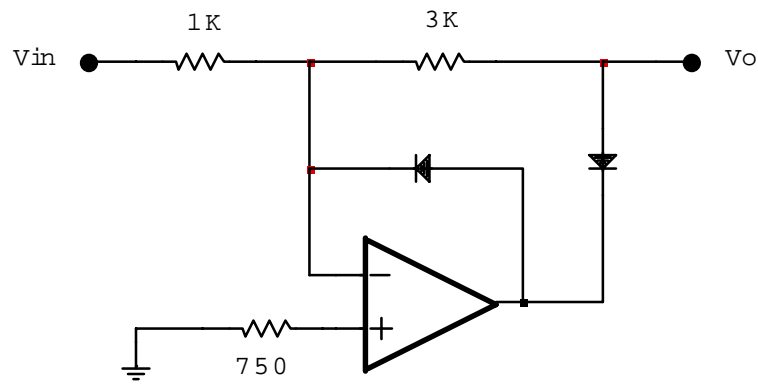
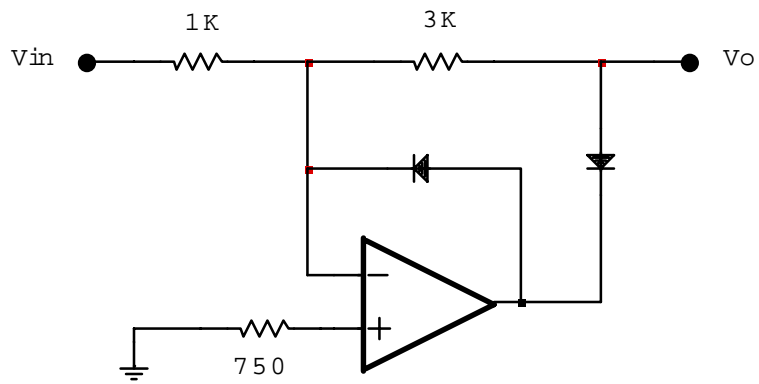

Show V_o waveform wrt V_{in} waveform.

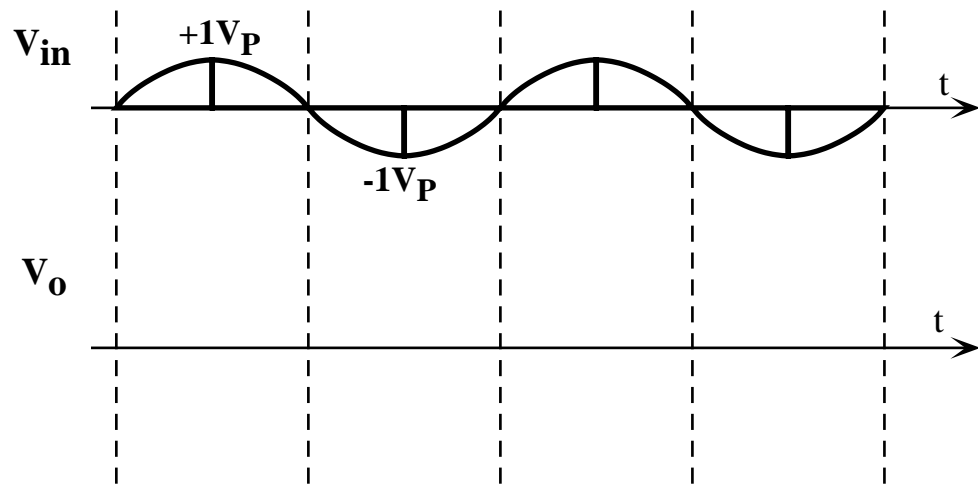

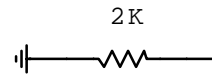
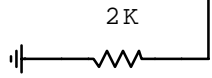

Show V_o waveform wrt V_{in} waveform.

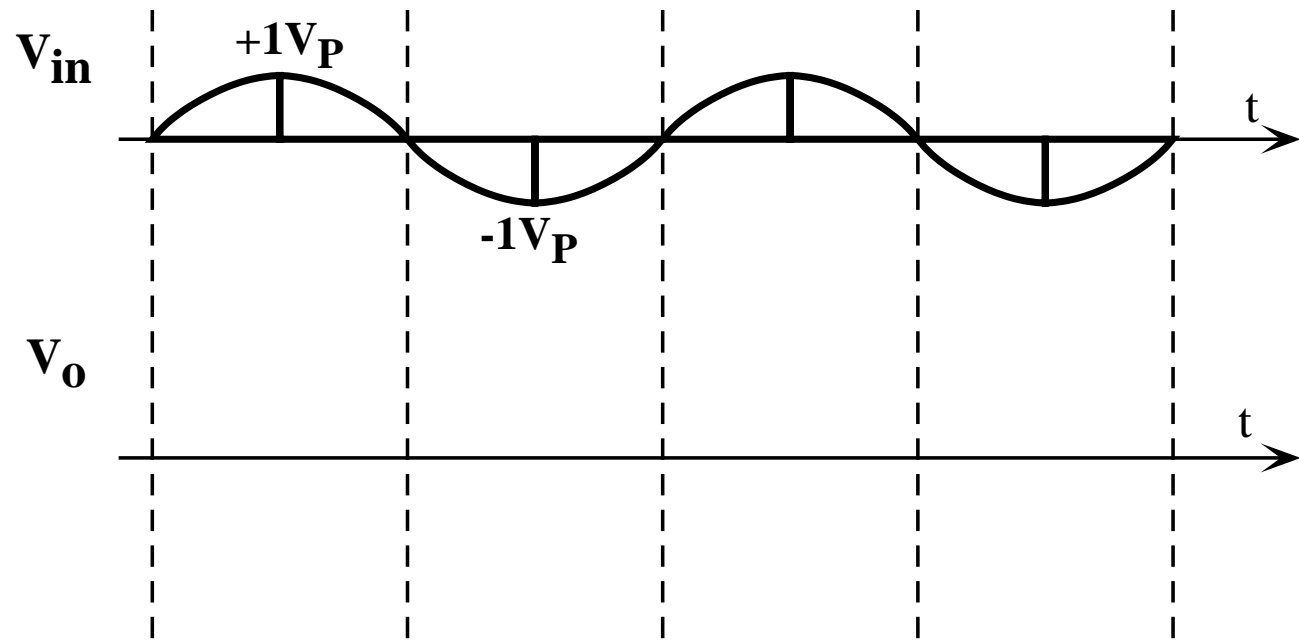

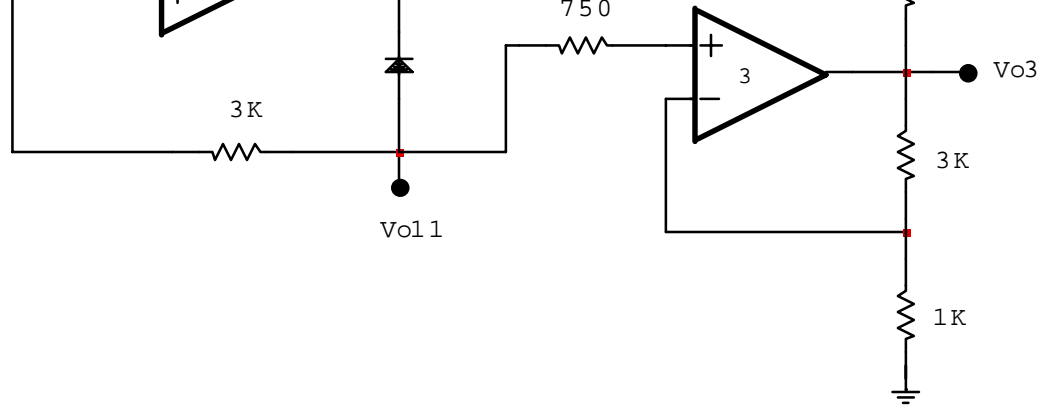

Show V_{o1} , V_{o11} , V_{o2} and V_{o3} waveforms wrt V_{in} waveform.

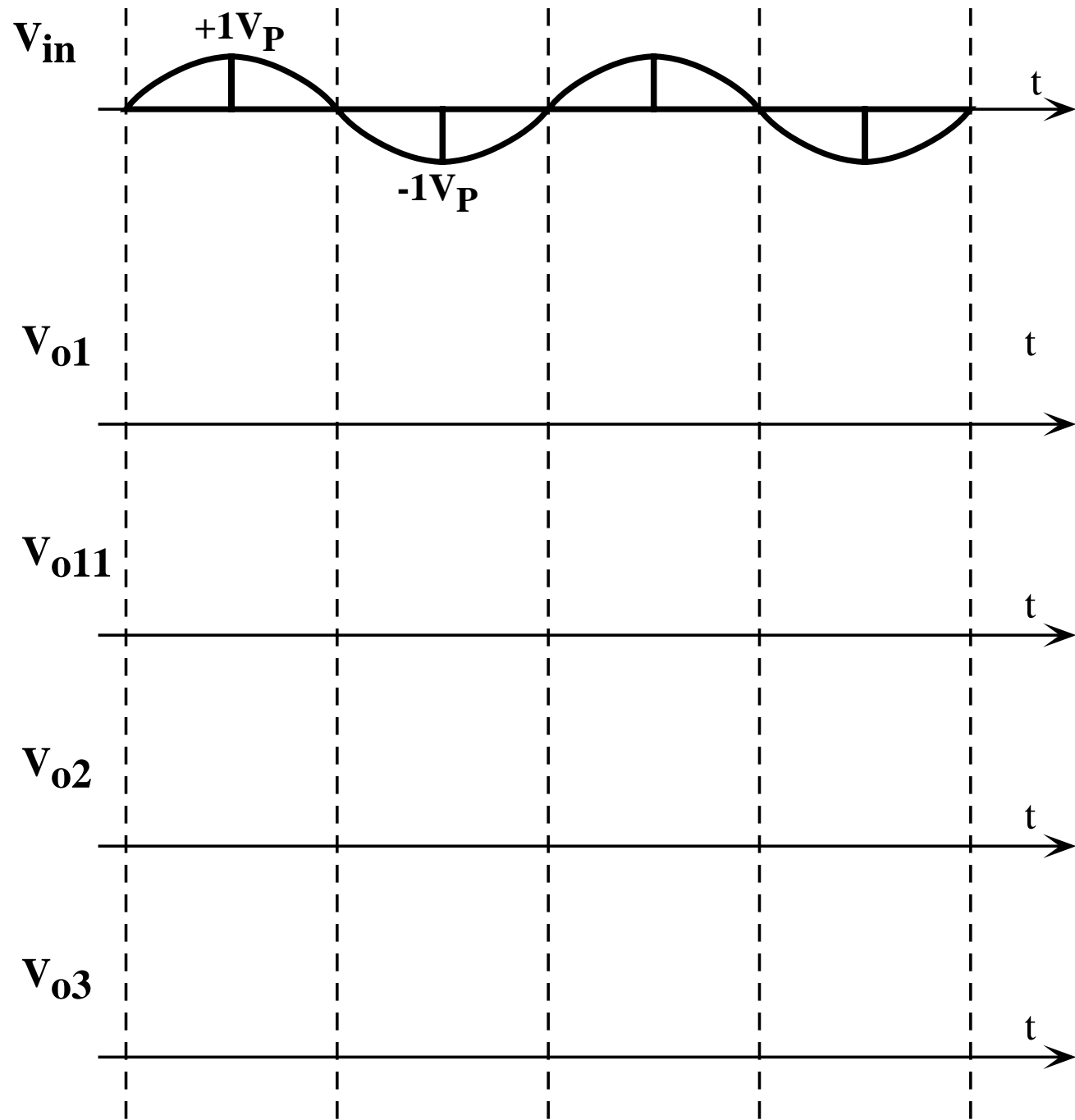

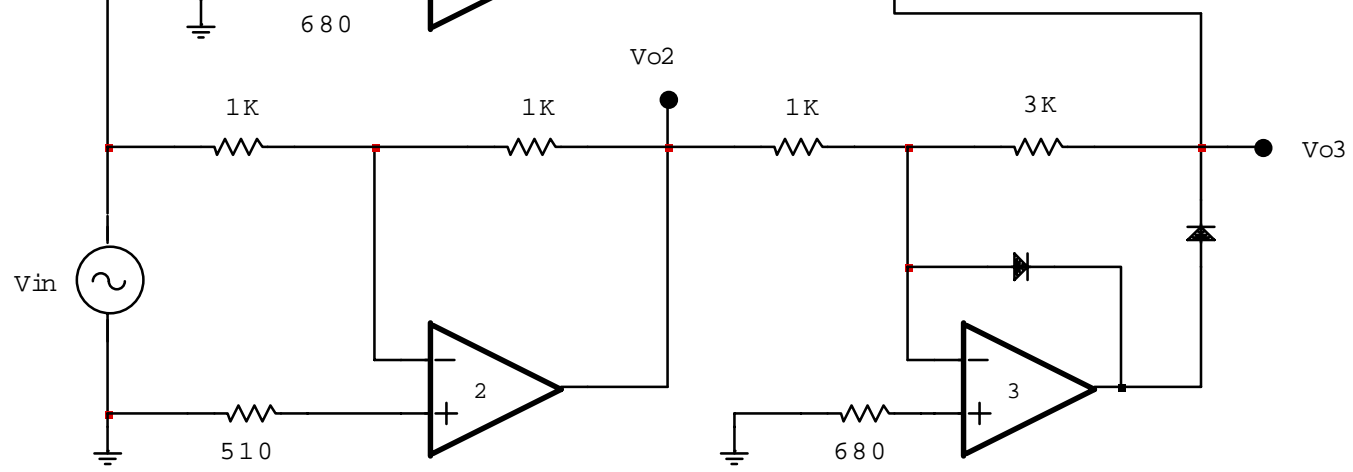

Show V_{o1} , V_{o2} , V_{o3} and V_{o4} waveforms wrt V_{in} waveform.

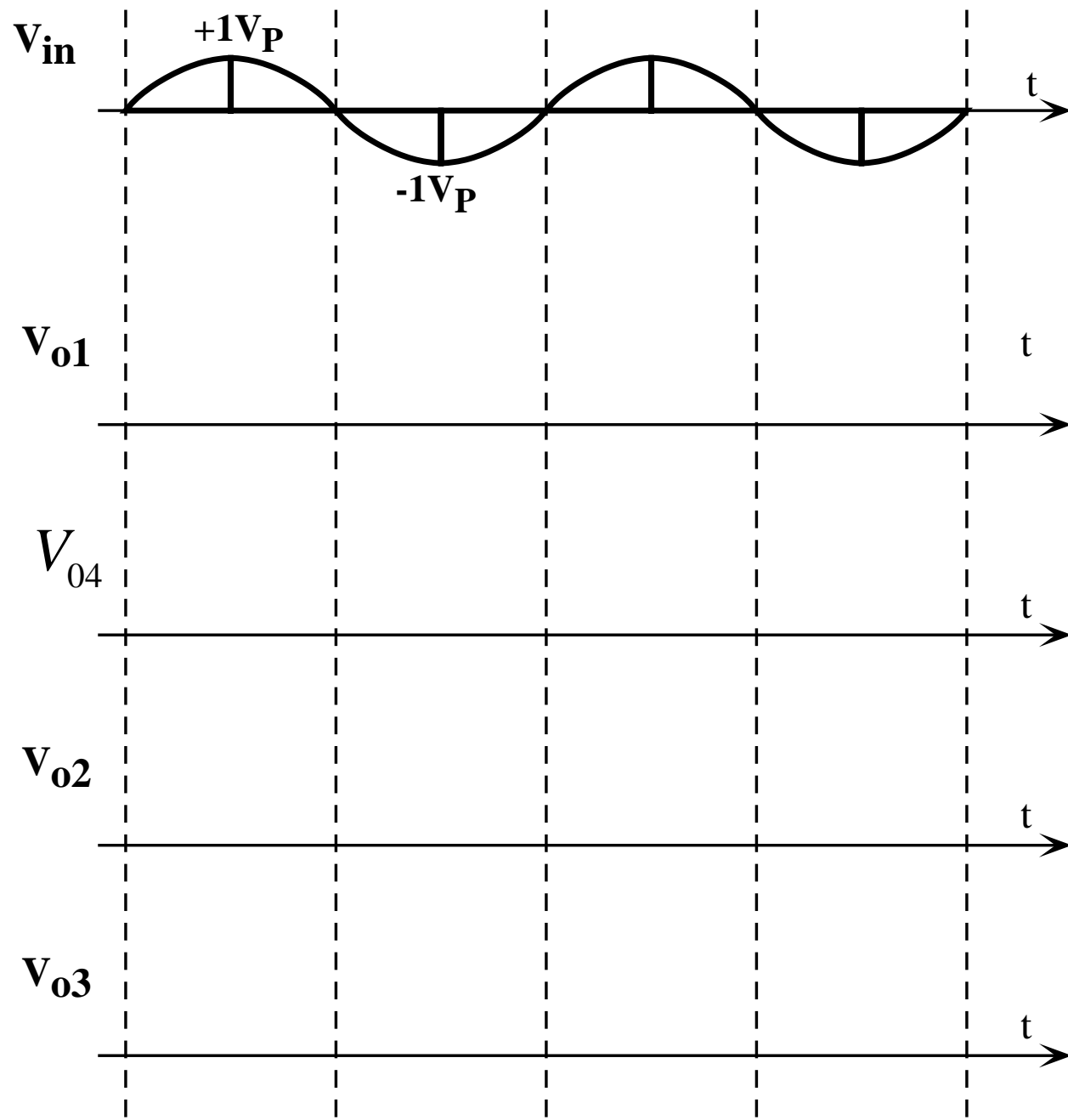

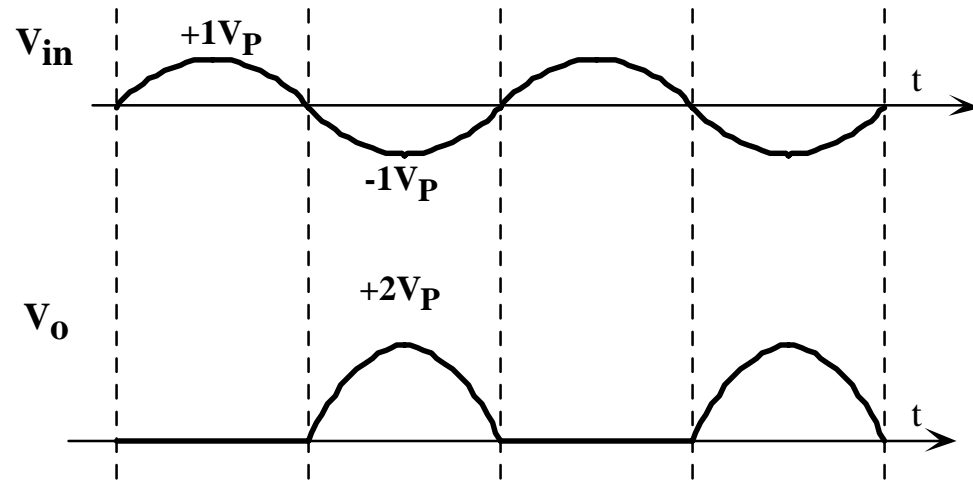
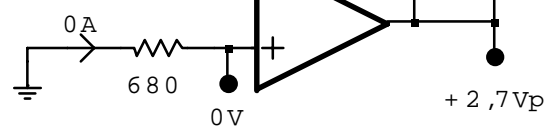
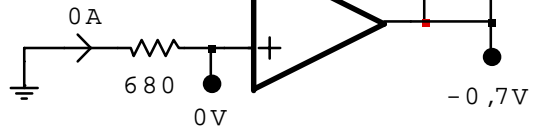

No.2

Positive Vin

Negative Vin

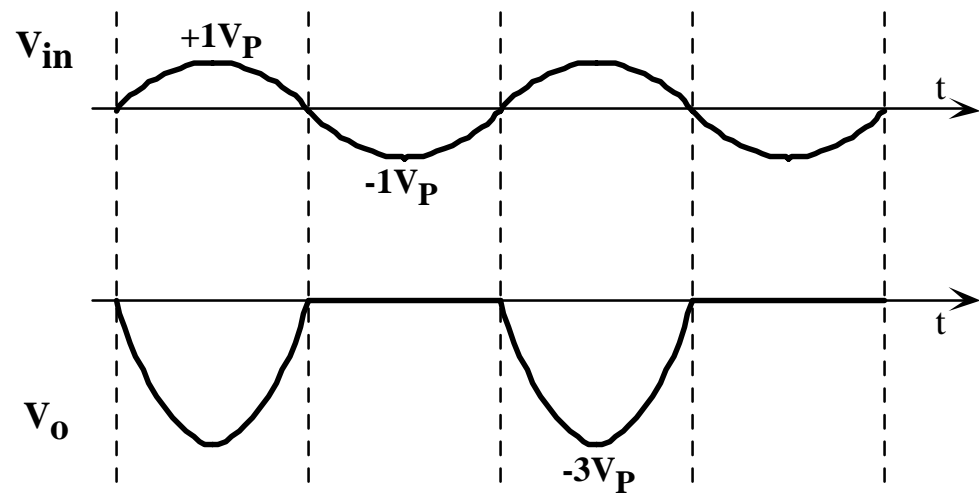
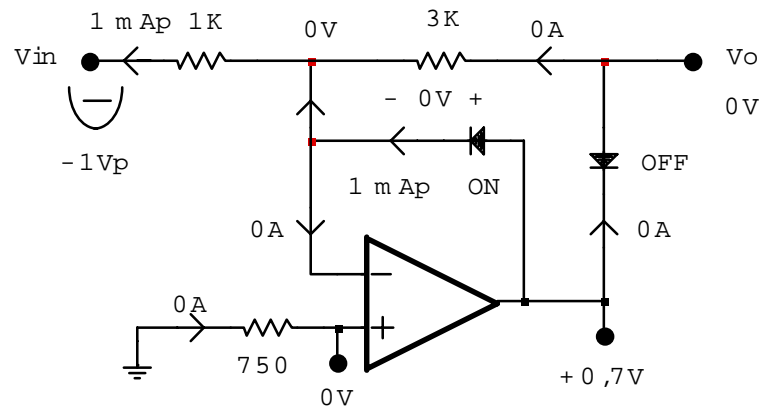
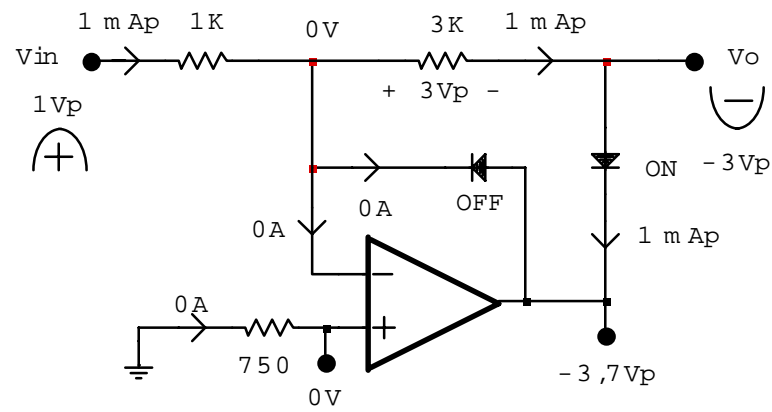

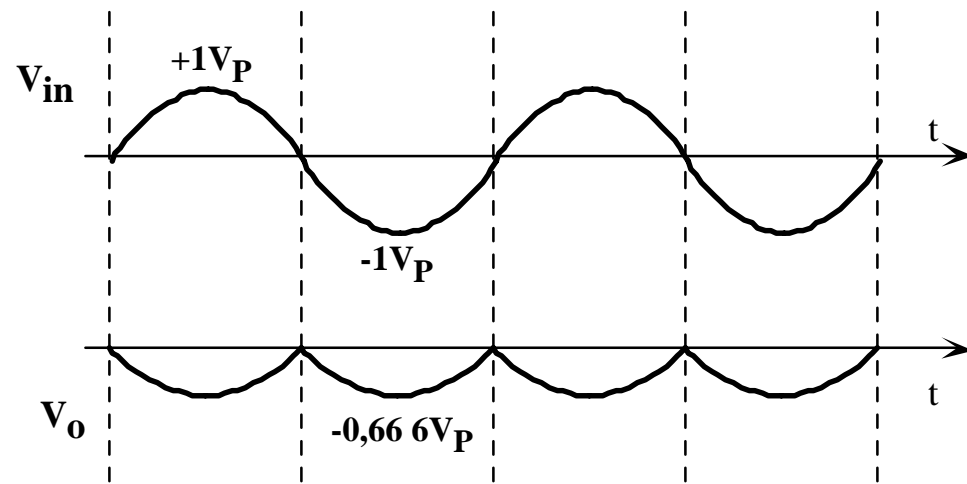

No.4

Positive Vin

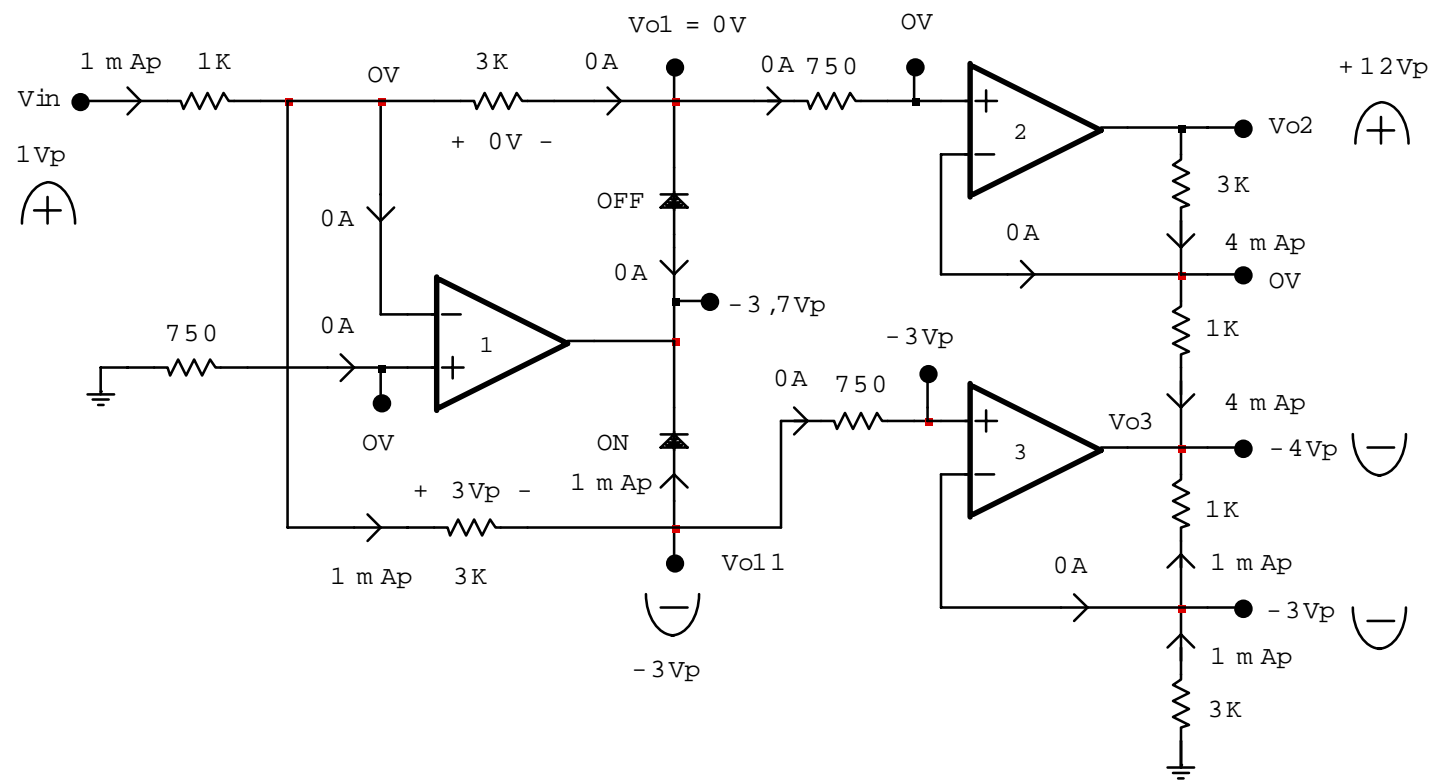

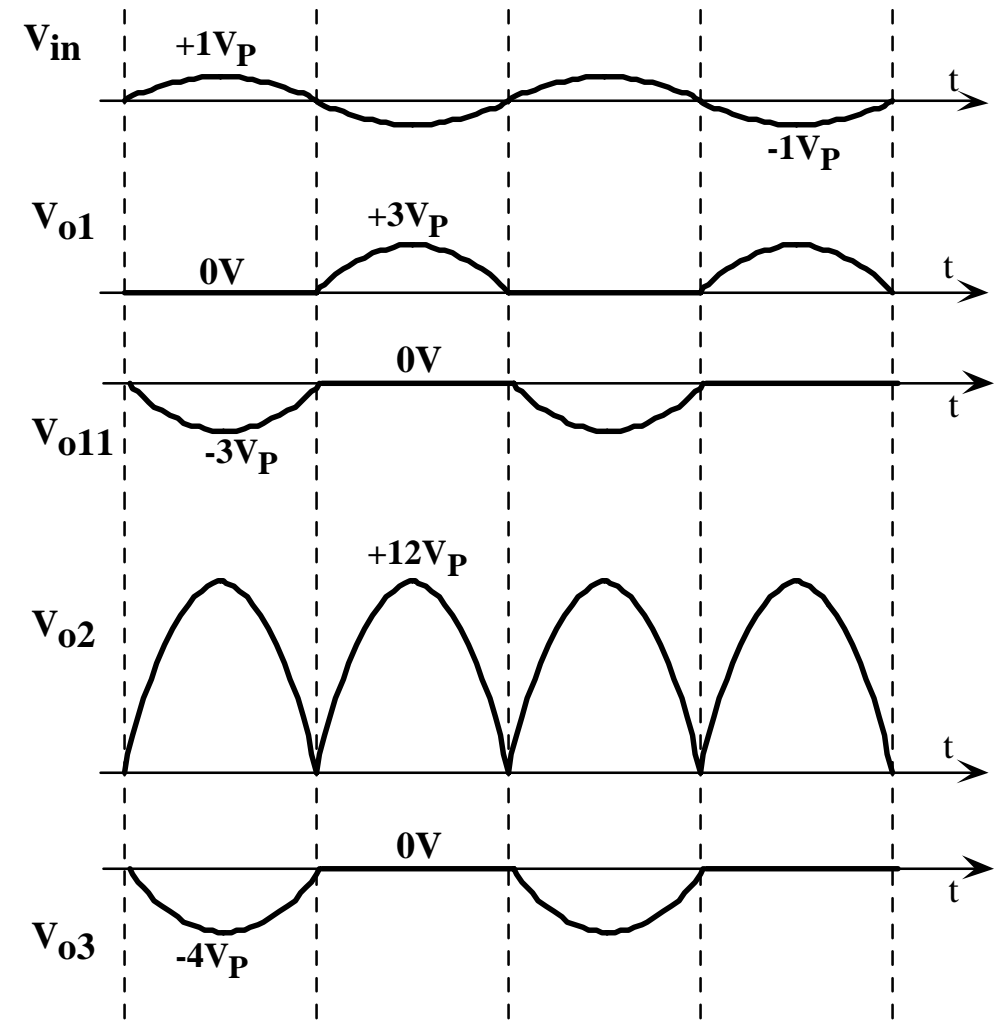
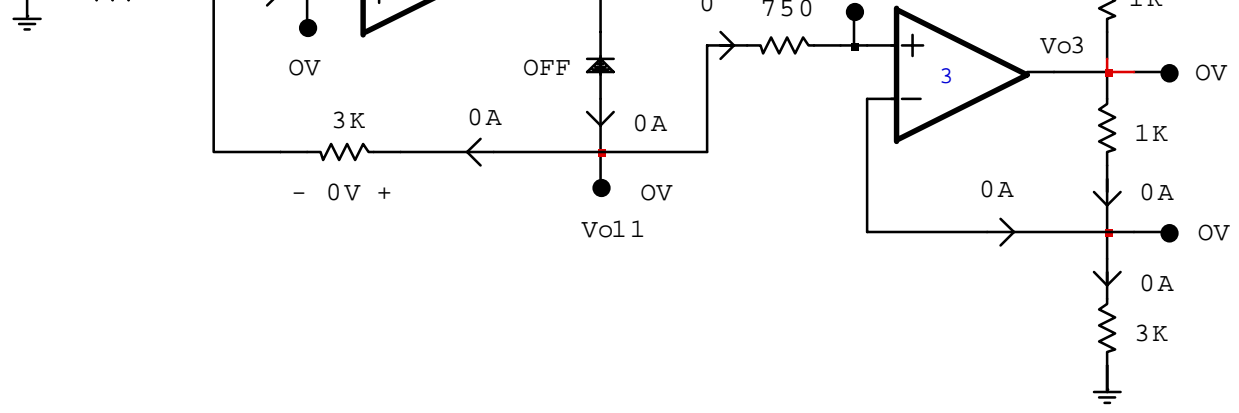

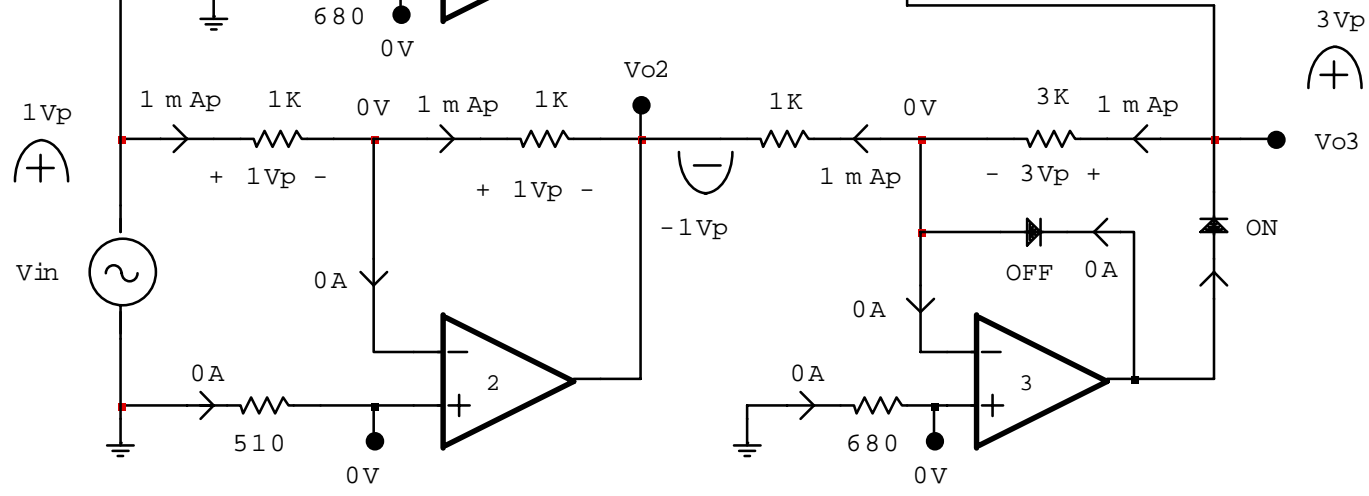

Negative Vin

